

INTRODUCTION

Plasma Injector 3 (PI3) is the 3rd in a sequence of reactor-scale experiments at General Fusion studying the physics and engineering needed to produce self-confined plasmas suitable for use as an MTF target plasma.

➤ **PI-1 and 2** explored high density (10^{22} m^{-3}), medium temperature (100 eV), and fast compression ($R_0/R = 4$, $\Delta t = 30 \mu\text{s}$) of a spheromak plasma using a 2-stage coaxial Marshall gun/railgun system. The accelerating railgun electrodes were conically converging to achieve the 4x radial compression to bridge the gap between the densities achievable with Marshall gun formation, and what was required for the initial state of the proposed MTF compression scenario.

➤ **PI3** is a single-stage coaxial Marshall gun for directly forming a spherical tokamak (ST) plasma target. This is a single-pulse fast CHI formation with no additional heating or current drive. Magnetic confinement is provided entirely by internal plasma currents and free-wheeling currents in the flux-conserving metal wall. PI3 will explore the plasma physics related to a slower MTF compression scenario where better thermal confinement times allow for lower densities, lower peak compression ratios and slower wall velocities. The PI3 device itself will not actually compress the plasma, but rather study basic physics objectives that are a prerequisite to building a large scale plasma compression experiment.

➤ **SPECTOR 1-5** devices are the latest in the PCS sequence of experiments, which are sub-scale (1/5th PI3 by radius) experiments to enable rapid development and testing of methods of plasma formation and compression by a moving metal wall. SPECTOR 1 is a lab-only device with an extensive set of diagnostics, SPECTOR 2-5 have been field mobile compression experiments.

STEPPING STONE TO MTF DEMONSTRATION

Plasma Injector 3 is part of an exploratory physics program needed to bridge the gap between existing subscale tests and a large scale plasma that has sufficiently good thermal confinement yet is produced by MTF-compatible methods.

The program objectives are:

- Explore the physics of MTF reactor-scale self-confined plasmas.
- Demonstrate performance goals on total inventory, magnetic flux, and energy confinement time. These goals are a >10x increase from previous MTF experiments completed by GF.
- Remove technical risks for building fullscale prototype of repetitively operated non-destructive compression device.

Plasma performance goals required to achieve net energy gain with a Magnetized Target Fusion (MTF) (nearly invariant among different possible schemes)

- Total particle inventory ($\sim 10^{21}$ ions),
- Sufficient magnetic flux ($\sim 0.3 \text{ Wb}$) to confine the plasma inventory without becoming MHD unstable
- Initial thermal energy confinement time several times longer than the compression time.

PI3 can also explore some of the more complex and flexible requirements exist not as a single value, but as a functional relationship between quantities;

- How thermal confinement time scales with key plasma parameters; this is a major input to reactor efficiency simulations, and would determine size and structure of future devices
- How edge physics and wall interactions scale with magnetic field strength, density, temperature. This would also be highly valuable inputs to guide simulation.

PLASMA INJECTOR 3 DESIGN DETAILS

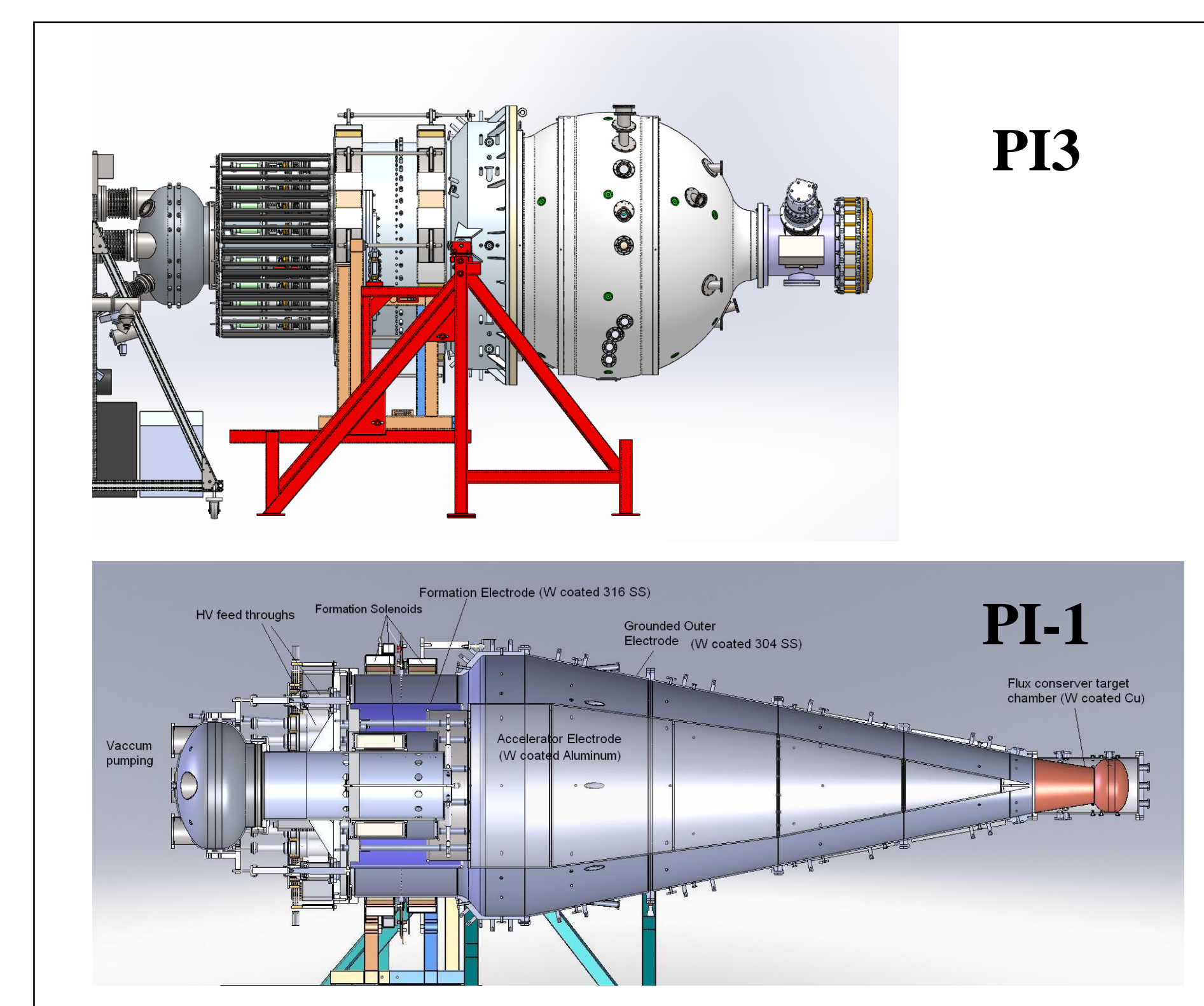
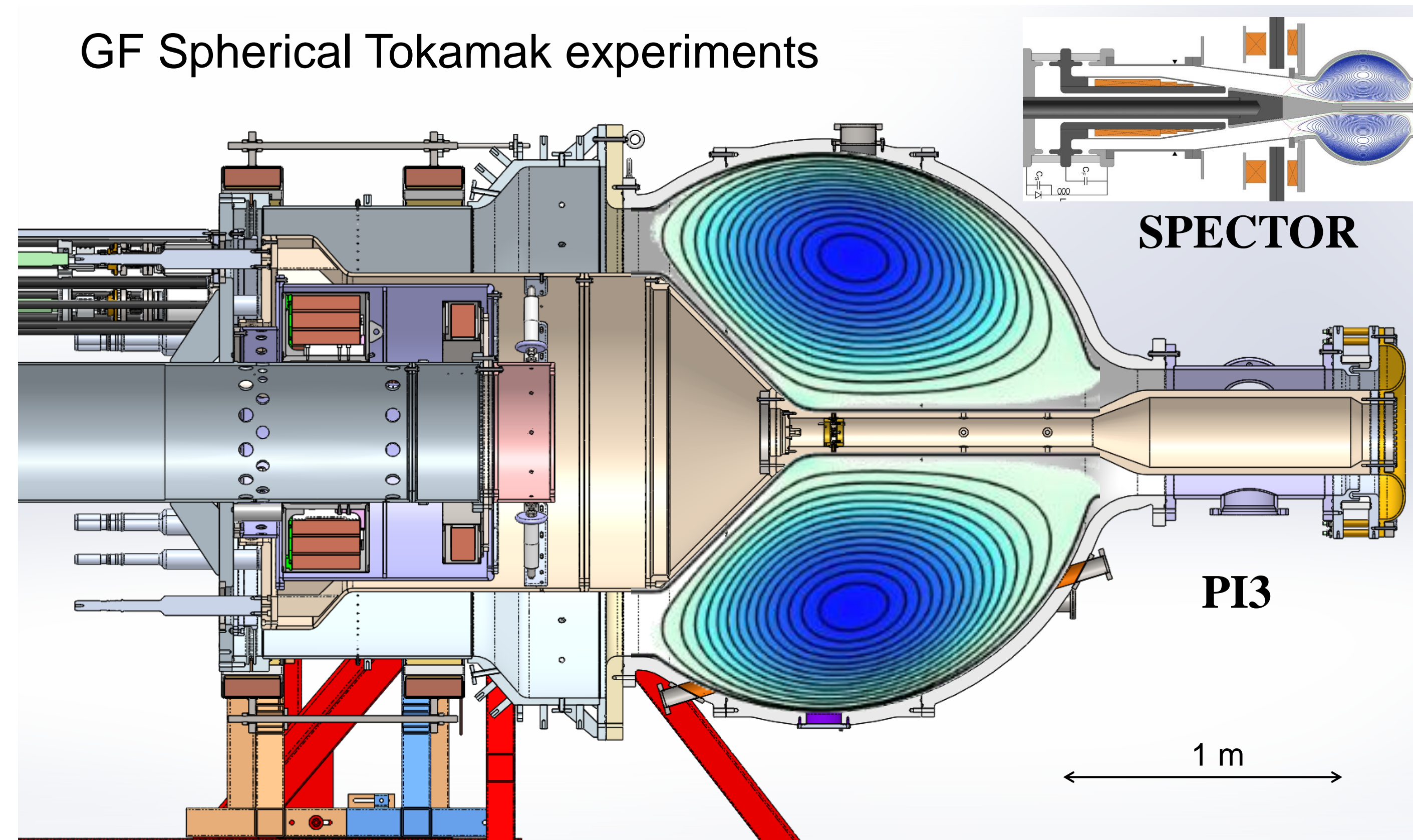

Parameter	Value range
Vessel inner radius	1 m
Major radius R	0.6 – 0.7 m
Minor radius a	0.3 – 0.4 m
Elongation κ	1 – 1.6
Triangularity δ	-0.15 – +0.1
Poloidal flux Ψ_{CT}	0.15 – 0.3 Wb
Plasma current I_p	0.3 – 0.6 MA
Shaft current I_s	1.0 – 1.3 MA
Plasma density n_e	$2 \times 10^{19} - 2 \times 10^{20} \text{ m}^{-3}$
Temperature $T_e \sim T_i$	100 – 500 eV
Beta β	2% - 8 %

PI3 will use a total of 10MJ in stored capacitor energy to create an ST configuration within an aluminum flux conserver. The capacitor bank is divided up into CHI formation of 1.5 MJ (2.5 mF, 35 kV), and then a 2-stage circuit to fill and sustain the vessel with sufficient toroidal flux for q-profile to be in the ST range, the first stage rapidly reaches peak current (1.3 MA) using 2 MJ (40 mF, 10 kV), followed by a second active crowbar stage of 6.4 MJ (128 mF, 10 kV) that maintains the current against resistive losses in the conductors. Formation poloidal field bias coils are powered by a bank of lead-acid batteries.

PI3 has enough similarity to the SPECTOR sequence of devices that increasing device radial size by 5x is expected to yield magnetic lifetime increase of 25x, while maximum temperature of PI3 is expected to be similar (400-500 eV) to what has been achieved on SPECTOR. PI3 has a factor of 10-20x increase of poloidal flux over the operating range of SPECTOR. In terms of total magnetic energy it is factor of 20x increase, in terms of total cap bank energy it is a 13.3x increase.

COMPARISON TO SPECTOR PARAMETER SPACE

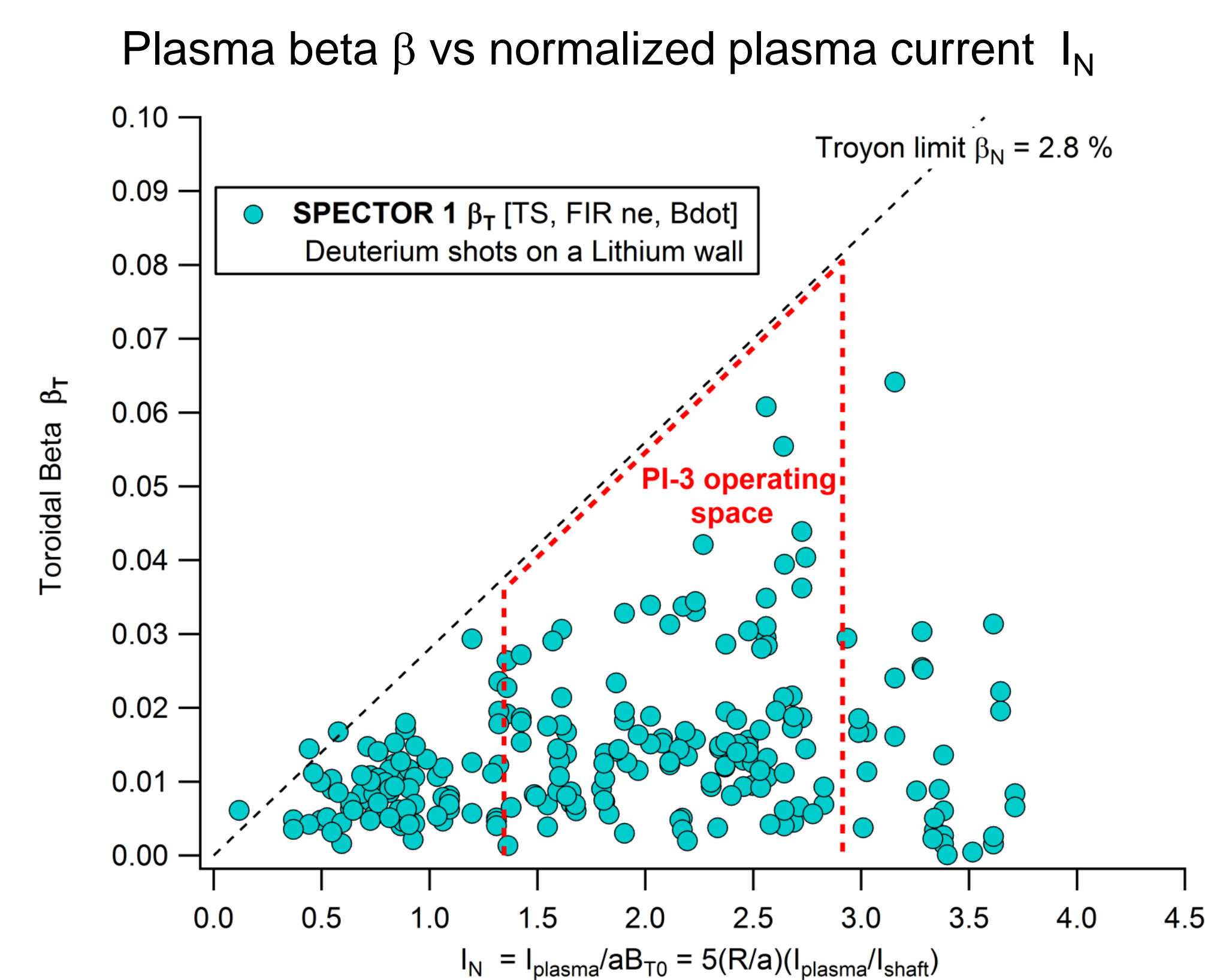

SPECTOR achieved its best performance in terms of temperature, overall magnetic lifetime, and plasma stability at a relatively low- β range, 1- 5% , bounded by the empirical Troyon limit for Ohmically heated tokamaks, which is reasonable considering SPECTOR's lack of additional heating.

PI3 is expected to operate in a similar range of β values. This should be acceptable for an MTF target plasma, the initial state before compression needs to be at moderately low β to prevent crossing a β -limit as the compression yields $\beta \sim R_0/R$ for the perfect adiabatic spherical case. This would convert initial $\beta_0 = 5\%$, into a peak value of $\beta_{Final} = 50\%$ in a 10:1 radial compression scenario.

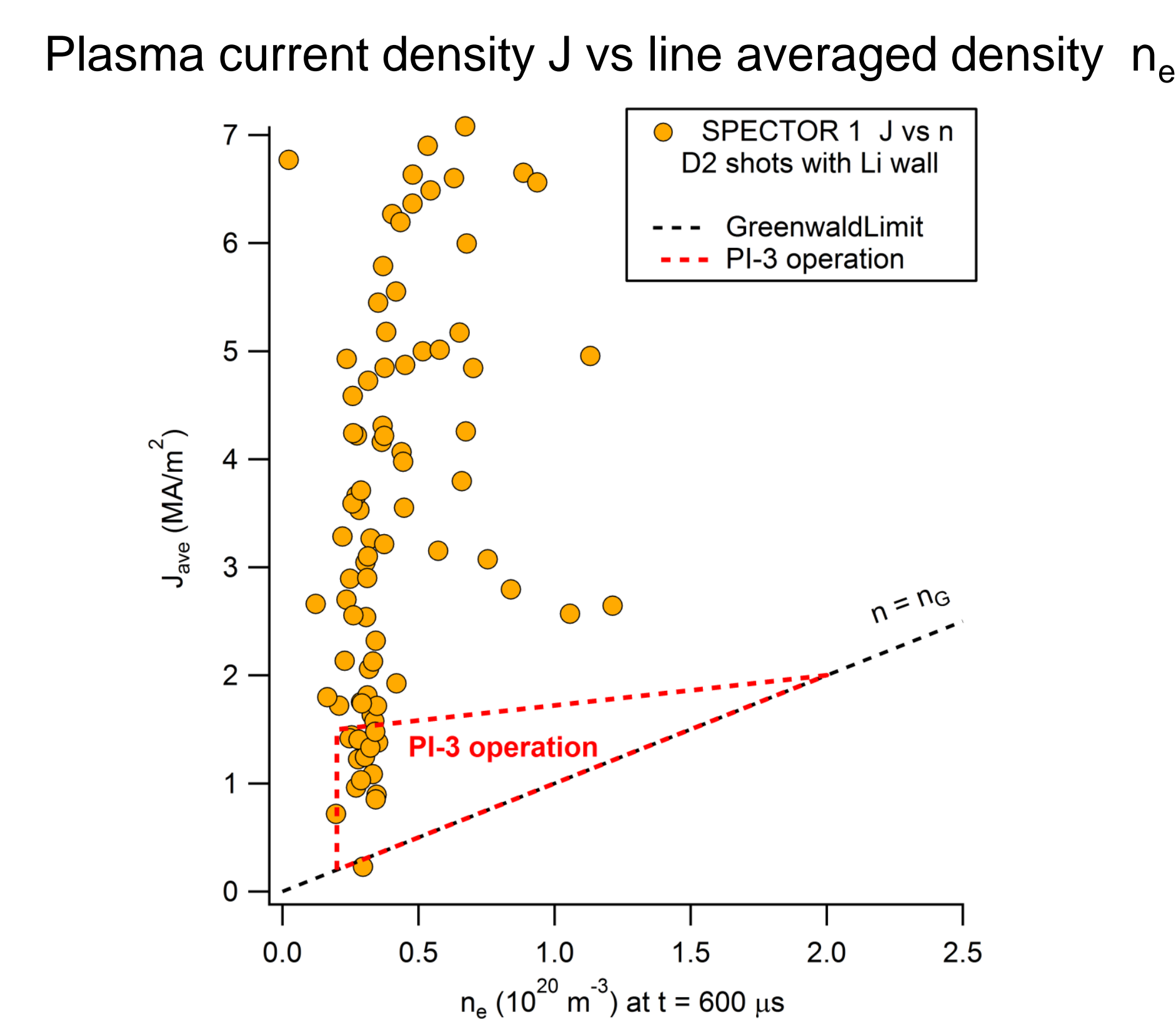

SPECTOR typically operated in the low-density edge of parameter space, just at the boundary of the run-way limit, confirmed by the detection of hard X-ray emission from a significant population of run-away electrons. High performance shots routinely achieved high temperature operation over a wide range of total plasma current.

PI3 will operate in the lower range of plasma current density J, and will instead work to explore higher density conditions near the Greenwald limit.

DIAGNOSTIC PLAN

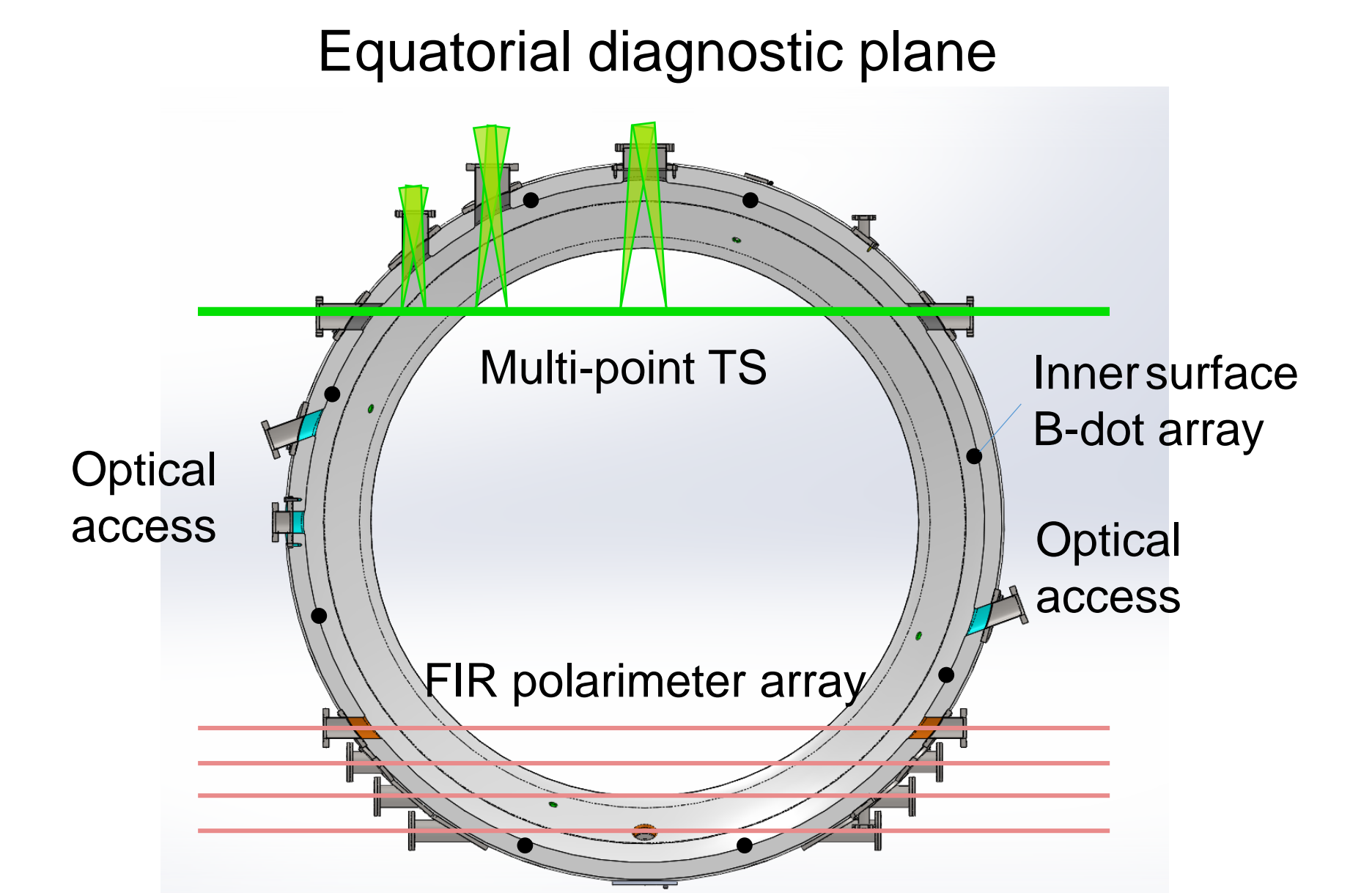

As part of the PI3 program, an extensive diagnostic system is planned, making use of existing hardware and methods already in place at GF, but also expanding capabilities where appropriate. Plasma temperature will be measured using a combination of multi-point Thomson scattering, ion Doppler spectroscopy, and soft X-ray radiometry. We are planning to extend the use of soft X-ray diagnostics to better constrain the position of the inversion radius during sawtooth oscillations. Soft X-ray and visible plasma imaging will watch for current filaments, edge density blobs, as well as constrain plasma shape and axial position. Magnetic structure will be determined from a synthesis of surface magnetic probe array data and reconstructions from the multi-chord FIR polarimeter array. Impurity composition will be assessed through time-resolved visible survey spectroscopy, VUV spectroscopy, and comparison to forward-modeled synthetic spectra.

PHYSICS INVESTIGATIONS

Measurement and control of plasma profiles

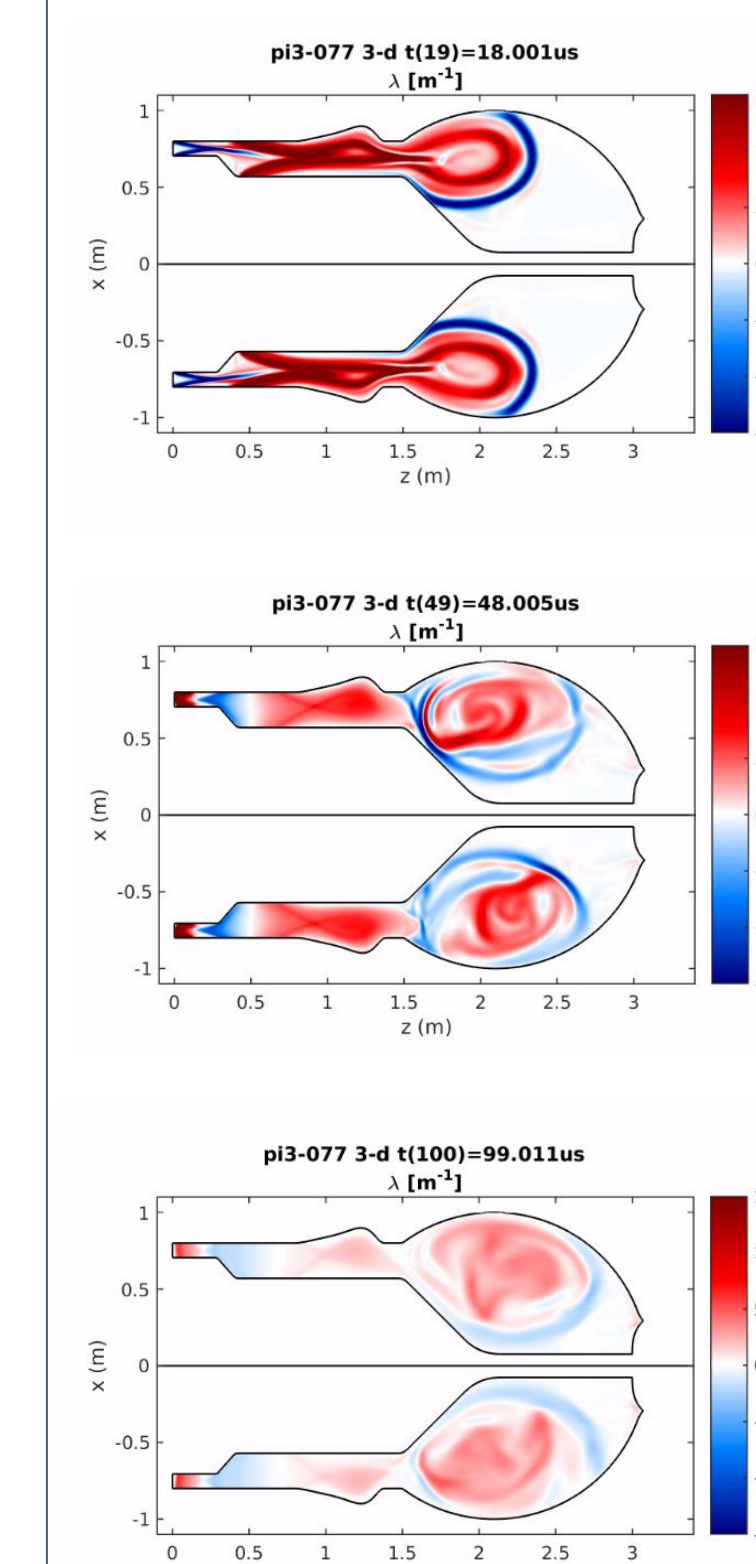

Lambda profile $\lambda(\psi) = \mu_0 J/B$ is critical for determining plasma volume, shape, Ohmic heating power and the magnetic L/R decay timescale. CHI formation relies on self-organization of plasma currents to converge on final equilibrium state. Evolution of safety factor $q(\psi)$ profile is determined by resistive MHD and choice of operational parameters for external circuit. MHD stability of the plasma as a whole is determined both by $q(\psi)$ and gradients in $\lambda(\psi)$. Temperature and density profiles will also be measured and combined with full set of diagnostic data to produce models of plasma structure and evolution.

Fluctuations and edge physics

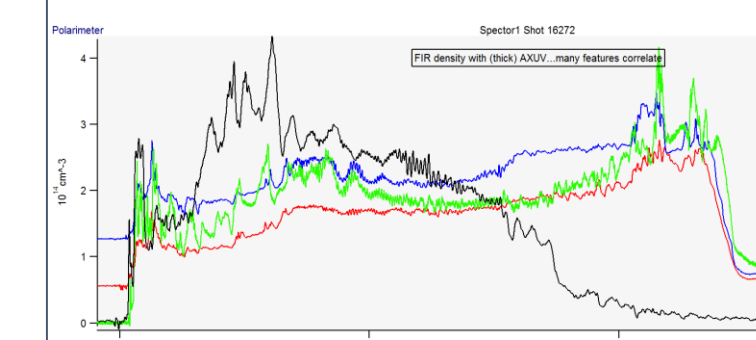

Analysis and modeling of fluctuation data, from magnetic probes, X-ray and optical radiometry, interferometry can provided constraints on plasma profiles and dynamic processes. Interaction with the wall and the physics within the edge region is critical to the work in MTF.

Transport and radiative losses

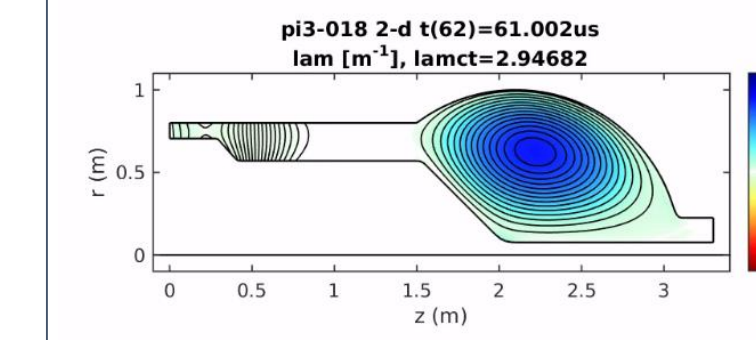

The ultimate goal of this work is to demonstrate sufficiently low thermal losses that significant heating can occur during MTF compression. Quantitative bounds on actual energy loss pathways are needed in order to better understand scaling laws for this class of self-organized ST plasma device.